

详细零部件&组装步骤

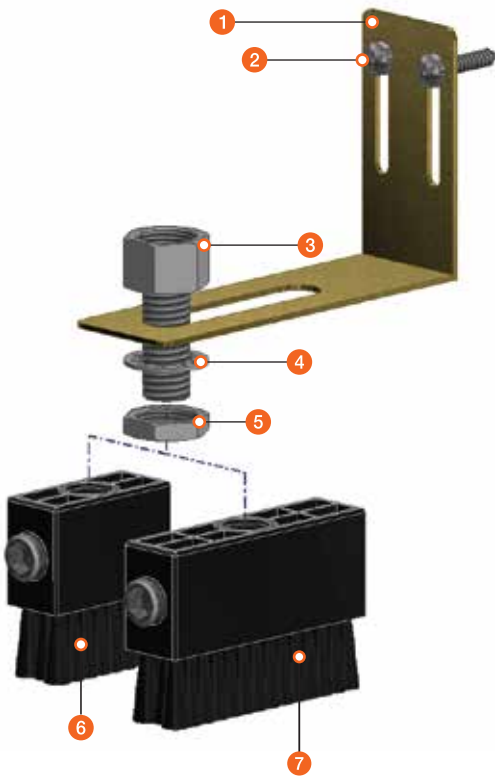

LIST	PART No.	DESCRIPTION	Q'TY
①	B003-01	Oil Brush Bracket, "L" Shape, Steel	1
②	B051	Self Drilling Screw, #8 x 19, Steel	2
③	A315	Reducer, PT3/8" F x PF1/4" Mx30mm x PT1/8" F, Steel	1
④	B058	Tooth Washer, O.D.23mm x I.D.14.5mm x 1t, Steel	1
⑤	N001	Nut, PF1/4" F x 5mm, Steel	1
⑥	C017	Oil Brush, 45 x 20 x 30mm Flat Nylon, PF1/4" F	1
⑦	C018	Oil Brush, 74 x 20 x 30mm Flat Nylon, PF1/4" F	1

组装步骤

1. 安装油刷支架 (①) 使用自攻螺丝钉固定在合适的位置 (②).
2. 固定接头 (③), 牙垫圈 (④), 螺母 (⑤) Pulsarlube OL500 装置沿着支架槽安装在所需位置 末端连接到合适的油刷 (⑥) 或 (⑦).

注释

排量因油粘度, 环境或温度等有所不同.

LIST & PART No.	KIT No.	DESCRIPTION
[① ~ ⑤] + ⑥ (C017)	C044	[OL] 45mm Nylon Flat Oil Brush & Bracket Kit
[① ~ ⑤] + ⑦ (C018)	C045	[OL] 74mm Nylon Flat Oil Brush & Bracket Kit